

Constitution Beach Concept Overview

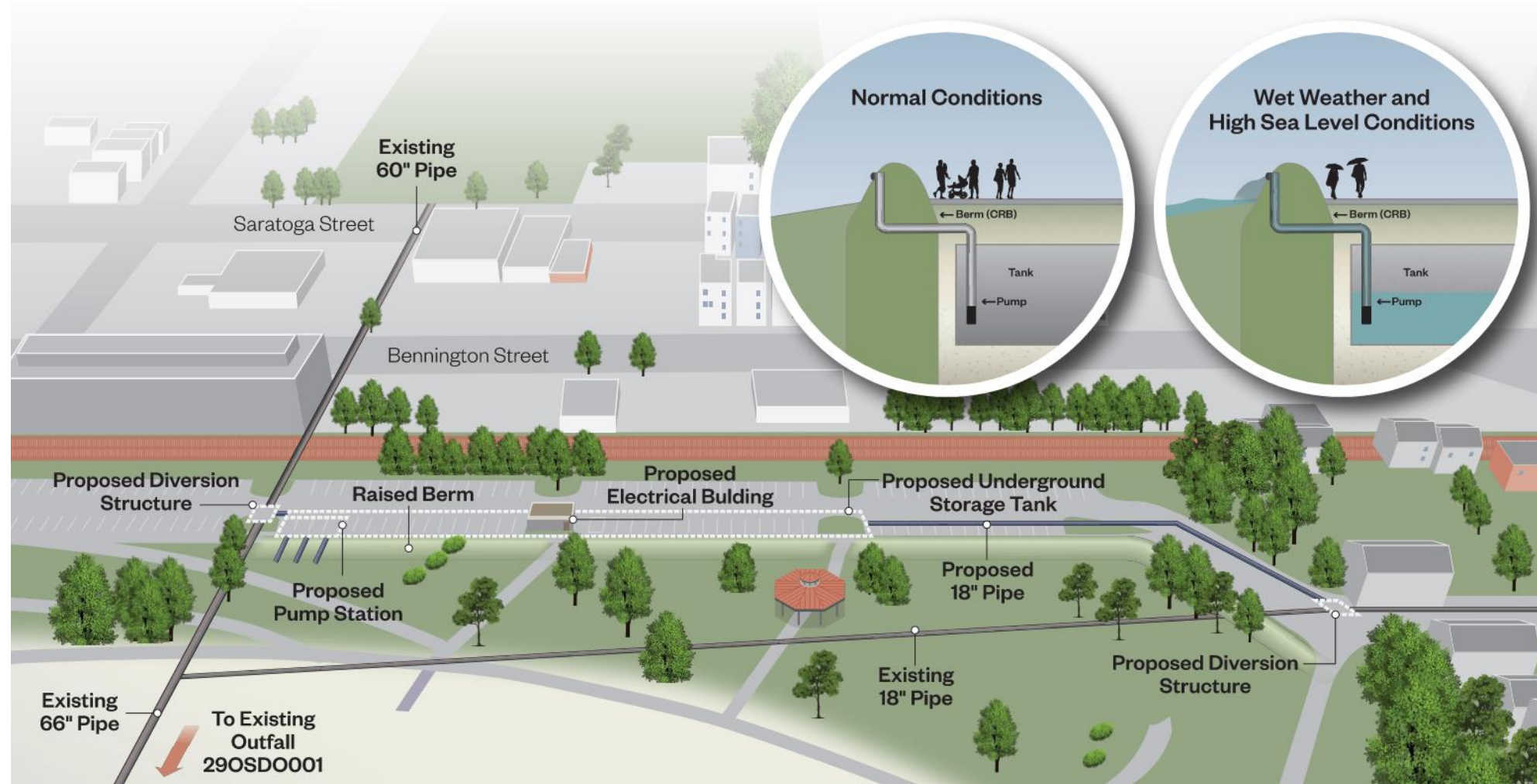

Conceptual Solution

The Constitution Beach concept design includes a subsurface stormwater storage tank and an underground stormwater pump station to discharge wet weather flow from outfalls 29OSDO001, 29PSDO44, and 28PSDO1 when sea levels are too high for the outfalls to discharge by gravity. Flow to the storage tank is diverted from existing sewers with passive diversion weirs, where proposed pipes then convey the flow to the storage tank. The storage tank is connected directly to the pump station. The pump stations utilizes electric submersible pumps to minimize the above ground footprint of the station and mitigate negative visual and auditory impacts from diesel engine driven pumps. Each pump is designed with its own, non-manifolded, discharge. During extreme storm conditions a portable generator could be parked within the parking lot to provide a backup power supply in the event of a power outage.

The location of the pump station discharge at this location is determined primarily by preliminary CRB adaptation plans, which include shoreline elevation and berms along the outer perimeter of the parking lot. During an extreme storm condition, it is anticipated that any area not protected by the berm would be flooded.

Type: Pumping and Storage

Total Drainage Area: 251 acres

Coastal Flood Vulnerable Drainage Area Protected: 239 acres

Concept Elements:

- Subsurface Storage Tank
- Subsurface Pump Station
- Diversion structures
- New conveyance

Outfalls Included in Concept:

- 29OSDO001
- 29PSDO44
- 28PSDO1

Coastal Stormwater Discharge Analysis
Constitution Beach



Assumptions

Sea Level Rise and Datum

The Constitution Beach Pump Station concept was designed for consistency with Climate Ready Boston (CRB) proposed adaptations and analyzed based on sea level rise (SLR) projections in the Massachusetts Coastal Flood Risk Model (MC-FRM). The SLR values applied in MC-FRM are consistent with the standards for the State of Massachusetts developed by Coastal Zone Management. The MC-FRM utilizes a “High” SLR scenario. This scenario is based on the relative SLR projections under Relative Concentration Pathway (RCP) 8.5 (a “worst case scenario” of increasing atmospheric carbon concentrations) and represents elevations that have a 99.5% probability of not being exceeded within the respective timeframes. In 2030 that amounts to an increase of 1.3 feet in Boston from a baseline condition (2008 centered tidal epoch), and in 2070 that amounts to an increase of 4.3 feet.

The concept developed in this project was analyzed using coastal conditions that include 2070 projected SLR and storm surge resulting from a 100-year tropical storm. The peak water surface elevation (WSE) predicted by the MC-FRM during these conditions is approximately 13.8 feet NAVD88 (varies by location). In mid 2022, the Greater Boston Research Advisory Group (BRAG) issued an updated report with new SLR projections. The report acknowledges that long term SLR projections are associated with significant uncertainty, and that updated projections include less SLR by 2100 (compared to earlier projections in the 2015 BRAG Report). According to the report, the likely range of SLR by 2070 under an RCP 8.5 scenario is 1.4 – 2.8 feet. Based on this information, projections from the MC-FRM that were utilized in this project are conservative and appropriate for long term planning purposes.

Unless otherwise noted, all elevations are based on the NAVD88 vertical datum. Elevations given in NAVD88 can be converted to Boston City Base (BCB) elevation by adding 6.46 feet.

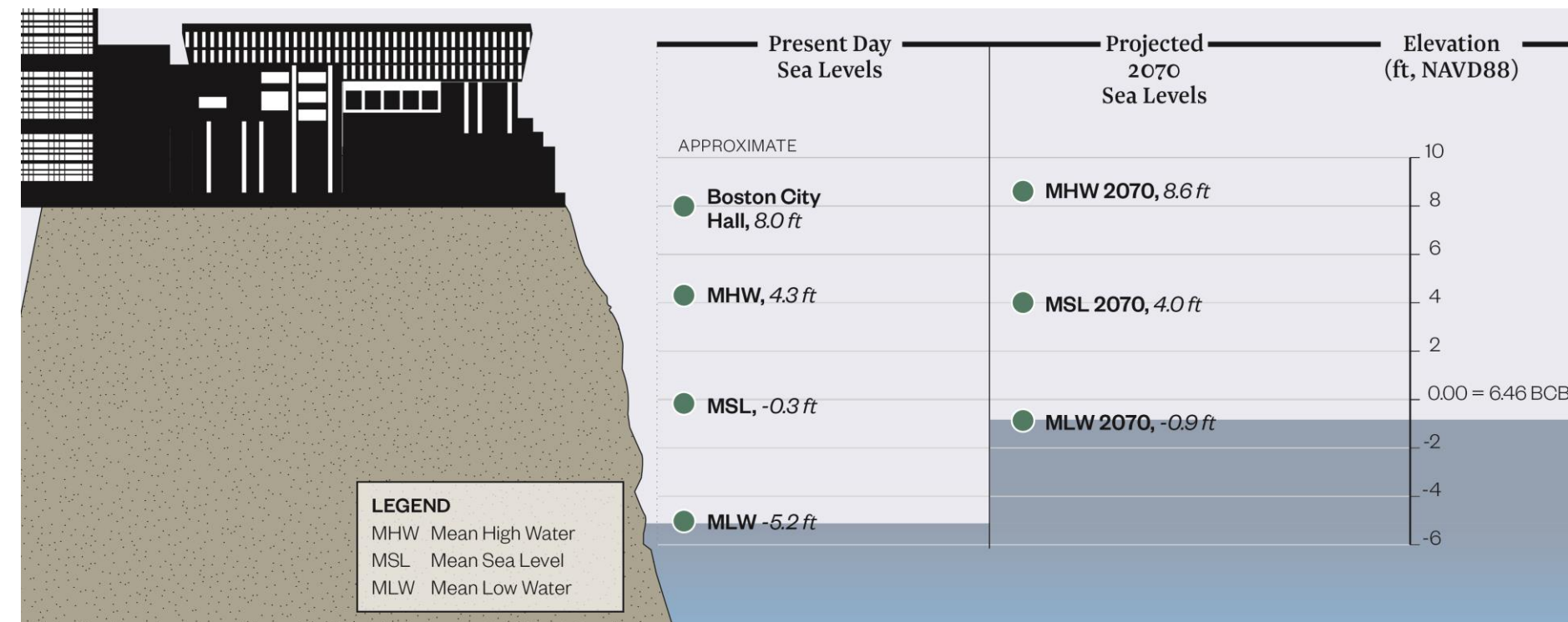



Climate Ready Boston and Shoreline Protection

The Constitution Beach Pump Station concept was developed to maintain consistency with possible Climate Ready Boston (CRB) adaptations based on the latest available information at the time they were developed. As the CRB program continues to evolve, it is anticipated that proposed concepts will need to be adapted.

The concept was developed to be consistent with stated neighborhood design flood elevations. In East Boston, where the stated design flood elevation is 16.0 feet, pumps were designed to discharge to a minimum elevation of 16.0 feet.

At the time of this project, many CRB concepts were in early planning stages and not fully defined. **In consideration of this, it was assumed the shoreline protection around the City of Boston is 100% effective for all modeling evaluations.** This assumption eliminates overland coastal flooding from model predictions, allowing for isolation of flooding that results only from rainfall and stormwater that cannot be discharged due to high sea levels. It is important to recognize that additional flooding, beyond what is depicted herein, would be expected if 100% effective shoreline protection is not implemented.

Coastal Stormwater Discharge Analysis
Constitution Beach

Sheet 2 of 10 | November 2022

Basis of Design

Storage and Pumping

Model simulations were conducted to determine the maximum Hydraulic Grade Line (HGL) that occurs at Outfalls 29OSDO001, 29PSDO44, and 28PSDO1 with the current tide cycle. Analyses were then conducted to determine the acceptable combinations of storage volume and pumping rate required to maintain the existing HGL with 2070 projected sea level rise and 100-year storm surge, as shown in Figure 1. The City of Boston's Parcel database was used to identify publicly owned parcels near the existing outfall. An analysis of the pump station was performed to identify a pump rate and physical dimensions that are hydraulically viable. It was found that a 1.4 MG storage tank ~23 feet deep could fit within the parking lot of the property with a 150 CFS pump station. The storage tank and pump station occupy an area of 11,935 ft². Each pump has a separate discharge force main which carries water to the proposed CRB berm, currently planned to be placed next to the parking lot, where the discharge structure will be placed. The Constitution Beach pump station utilizes two duty pumps, one standby pump, and two dewatering pumps. The pump station is configured with vertical, axial electric submersible pumps in parallel bays.

Figure 1: Outfall 29OSDO001 Storage vs. Pumping

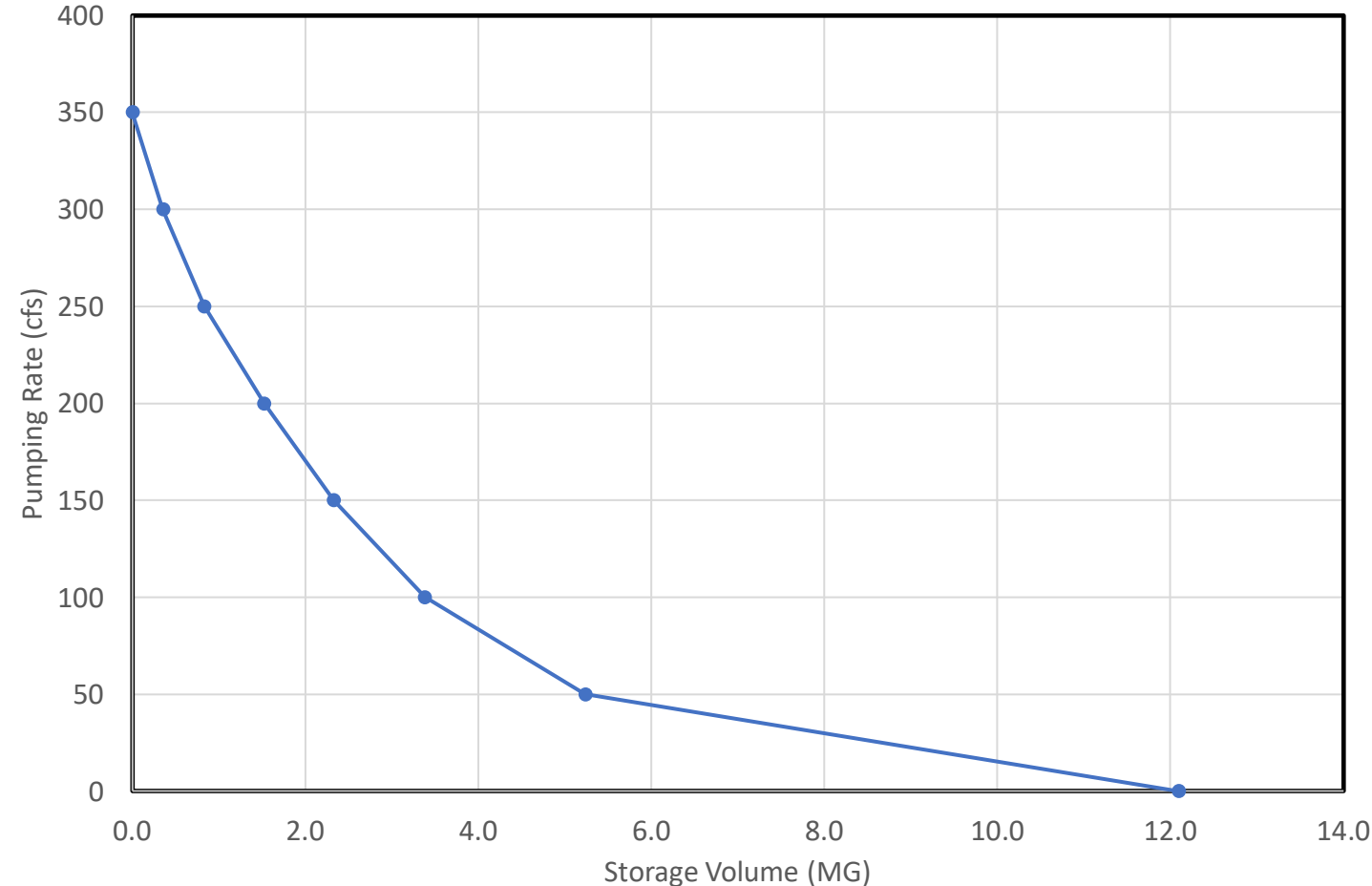

Rainfall and Coastal Conditions

The Commission currently utilizes a 10-year, 24-hour design storm to establish its target level of service. For the purpose of sizing new piping and evaluating storage capacity, a projected 2070 10-year, 24-hour design storm was developed. For consistency with Climate Ready Boston, performance of the DBB storage concept was also evaluated with projected rainfall from a 100-year tropical event (developed during the Commission's Inundation Model Project). The DBB was evaluated using a 100-year return period coastal boundary condition. Data for this condition were obtained from the MC-FRM. For the purpose of evaluating the effectiveness of the concept, it was further assumed that complete shoreline protection was implemented, preventing flow of water between land and the harbor/Neponset River. Table 2 contains a summary of the coastal conditions that were analyzed.

Table 1: Rainfall Conditions

Scenario	Purpose	Rainfall Depth (in)	Peak Intensity (in/hr)
Present Day, 10-year, 24-hr design storm	Baseline Conditions	5.15	3.32
Projected 2070, 10-year, 24-hr design storm	Design Conditions	6.18	4.08
100-year Tropical Storm	Damage Analysis	9.58	0.84

Table 2: Coastal Conditions

Scenario	Purpose	Peak Water Surface Elevation (ft, NAVD88)	Source
Present Day	Baseline Conditions	3.7	BWSC Existing Model (April 2016 Tide Cycle)
2070, 100-year Tropical Storm	Damage Analysis	13.8	MC-FRM

Coastal Stormwater Discharge Analysis
Constitution Beach



Hazen

Flood Modeling and Damage Analysis

Figure 2: Estimated Replacement Cost

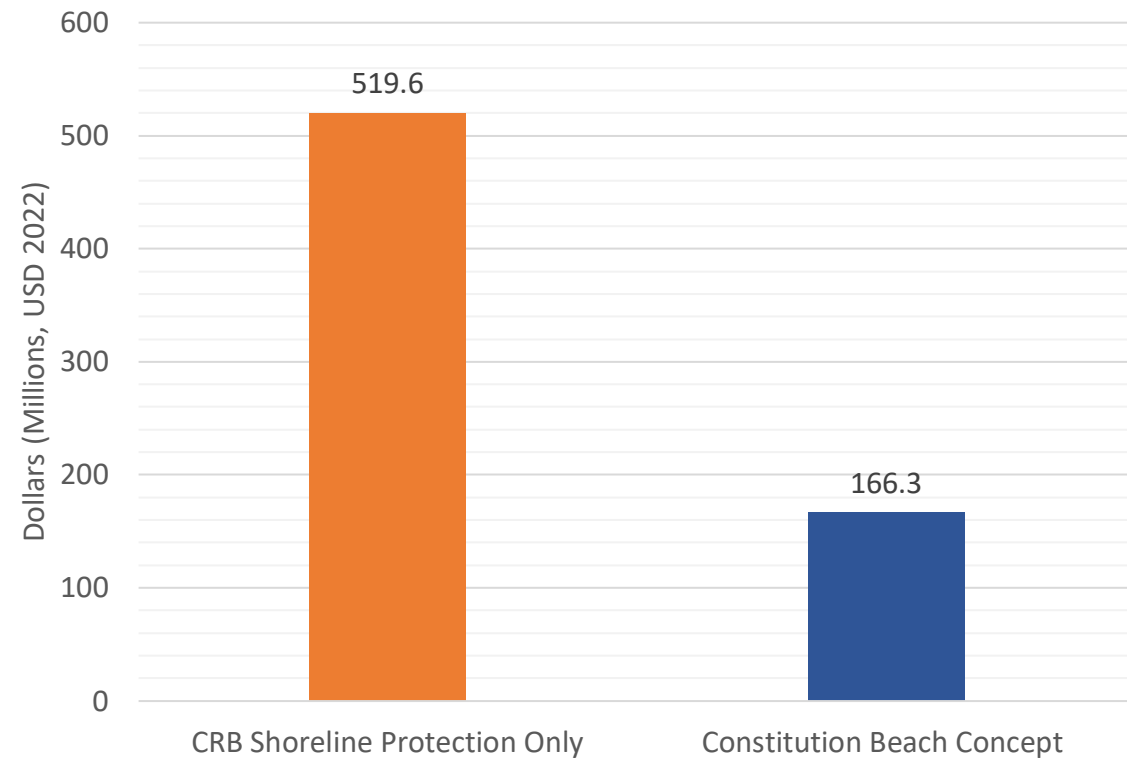

Figure 3: Loss of GDP

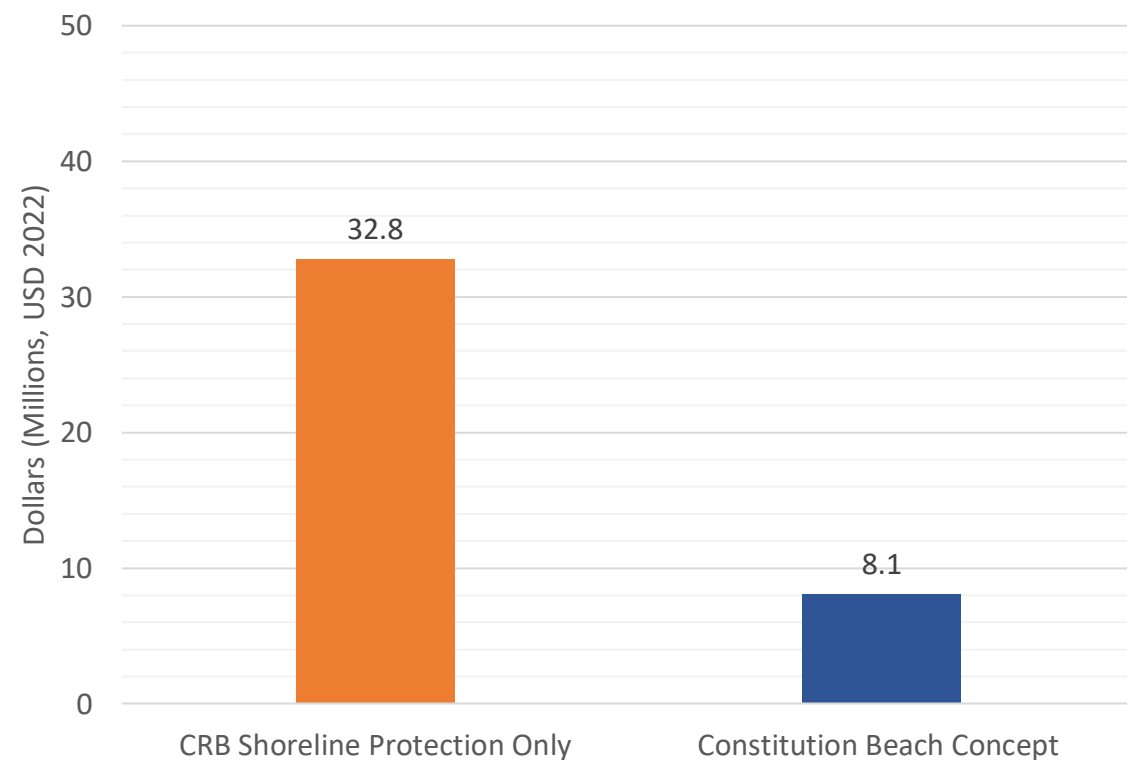
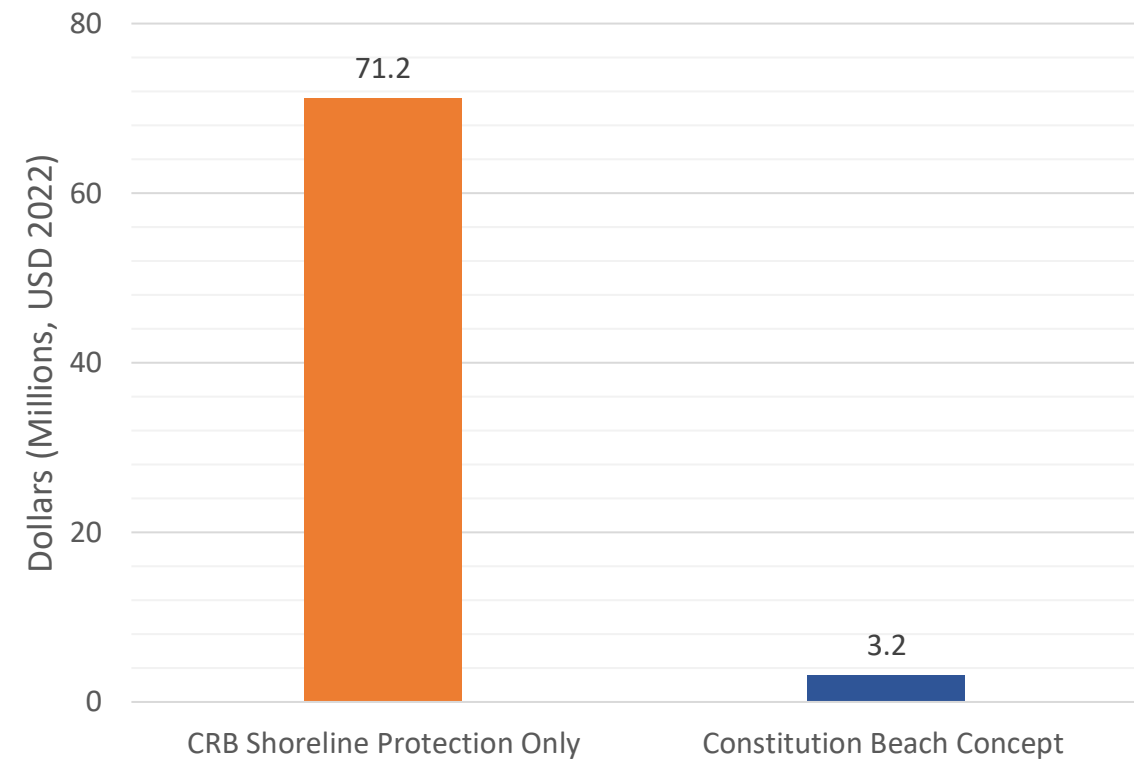

Figure 4: Physical Damage



The flood reduction benefits of the Constitution Beach concept were evaluated using the Commission’s 2D Inundation Model by simulating a 100-year tropical storm event with 2070 SLR and storm surge. The figures on the following page depict the peak flooding that was predicted in the Constitution Beach drainage area with shoreline protection only and with the pump station and tide gates on all vulnerable BWSC owned outfalls. An analysis of economic losses/physical impacts from flooding under both scenarios was performed by risQ Inc.

Model predictions indicate that **the Constitution Beach Pump Station concept reduces physical damage by \$68 million, avoids \$353.3 million in rebuilding costs, and mitigates a GPD loss of \$24.7 million** during a 100-year tropical storm event in 2070 compared to shoreline protection only.

Note: replacement values include the total value of impacted buildings in flooded areas (e.g., impacted buildings are fully replaced), whereas physical damage includes estimated costs to repair flood damage based on predicted flood depths and building characteristics. The values shown are the average of minimum and maximum calculated losses. Refer to the Project's Final Report for more information.

Coastal Stormwater Discharge Analysis
Constitution Beach



Hazen

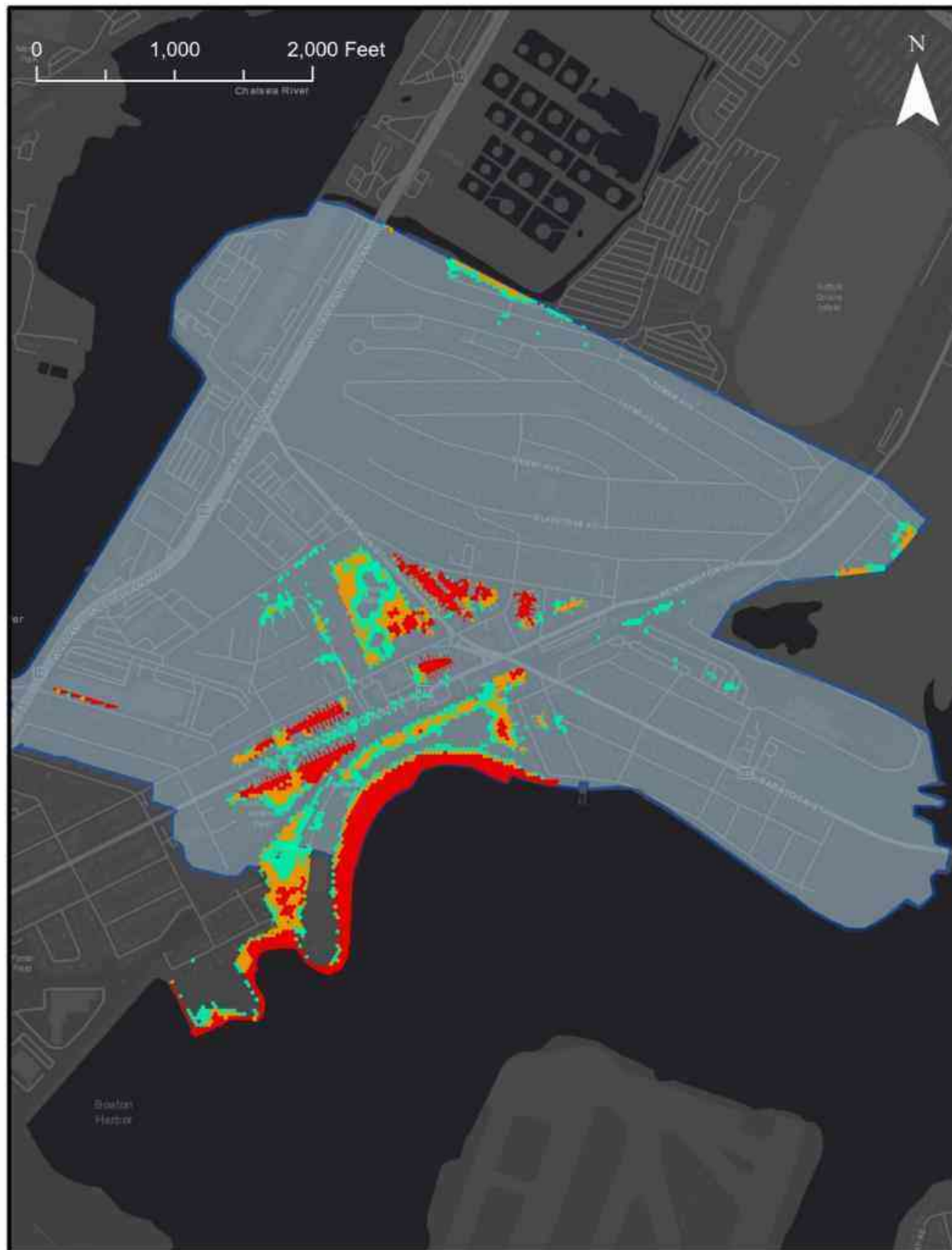

Legend

- Flood Depth > 4 in and < 1 ft
- Flood Depth > 1 ft and < 2 ft
- Flood Depth > 2 ft
- Drainage Area Analyzed



Simulation Parameters

Storm Type	100yr Tropical Storm
Rainfall Depth	9.6 inches
Peak WSE 2070 SLR + 100yr Surge	13.8 feet NAVD88

2070 SLR + 100yr Tropical Storm + Storm Surge
Shoreline Protection Only

2070 SLR + 100yr Tropical Storm + Storm Surge
**Constitution Beach Pump Station and
Tide Gates**

Coastal Stormwater Discharge Analysis
Constitution Beach

Sheet 5 of 10 November 2022

Cost Estimate and FEMA BRIC Considerations

Capital Cost Estimate

A construction cost estimate for the Constitution Beach concept was developed for planning purposes. Assumptions for the cost estimate include 15-year escalation to the mid-point of construction and the inclusion of a 50% design contingency. Utility hookup costs were not included.

Table 3: Constitution Beach Cost Estimate Subtotals

Remaining Design Development & Construction Administration (assumed 20% of total less design contingency)	\$3,870,000
Direct Construction Costs	\$7,615,841
Indirect Construction Costs	\$1,523,168
Mark-Up (Including 50% design contingency)	\$19,533,991
Total	\$32,543,000

Social Vulnerability and FEMA BRIC Funding

FEMA BRIC funding prioritizes disadvantaged communities. Table 4 contains a summary of several indicators for the Constitution Beach tributary area that could be used help characterize the community for future FEMA funding applications and prioritization of projects that benefit disadvantaged communities.

Table 4: Constitution Beach Tributary Area Social Vulnerability Indicators

Low Income & Persistent Poverty	
Per Capita Income	\$32,899
Below Poverty Line	16%
High Housing Cost Burden	
Stressed Renters (>40% rent-to-income)	18%
Households With Food Insecurity	14%
Racial and Ethnic Segregation	
Asian Population	4%
Black Population	3%
Hispanic Population	48%
White Population	67%
Education and Employment	
Adults Age 25+ Without High School (or equivalent) Degree	19%
Unemployment Rate (Age 16+)	11%

Data provided by risQ inc. from the US census and American Community Survey

Coastal Stormwater Discharge Analysis
Constitution Beach



Hazen

Sheet 6 of 10

November 2022

Planting Palette

A planting palette was developed for the greenspace bordering Constitution Beach. After construction, planting of native plant species could provide a public amenity with new green space and environmental benefits associated with native plant species.

Shrubs



Baccharis halimifolia
groundsel tree



Iva frutescens
saltmarsh elder



Prunus maritima
beach plum



Morella pensylvanica
bayberry

Herbaceous and Grasses



Spartina alterniflora
smooth cordgrass



Spartina patens
saltmeadow grass



Distichlis spicata
coastal salt grass



Solidago sempervirens
seaside goldenrod

Adaptability and Implementation

Adaptability

Figure 5 below depicts historical daily rainfall totals and tide levels. As shown in this figure, the conditions that were used to design and analyze the Constitution Beach pump station are conservative and represent more extreme conditions than have occurred historically. Regardless, the following measures could be implemented to adapt the concept to more severe conditions (additional SLR, more intense rainfall, etc.) in the future:

- Increase the size of installed electric submersible pumps
- Utilize the standby pump as a duty pump during extreme conditions
- Increase the size of peak shaving tank

Implementation Considerations

- Coordination with CRB is necessary to implement shoreline protection. The pump station should not be implemented without shoreline protection to prevent coastal flooding within the area tributary to it.
- Planting of native plant species and other green features will provide an improved public amenity and preserve the “look and feel” of the parking lot and surrounding park.
- Community engagement with stakeholders may help build project support by illustrating the flood control benefits of the pump station.
- A comprehensive permitting evaluation should be conducted to evaluate possible impacts from construction and operation of the pump station to the receiving water.
- The location of the pump station and discharge should be adapted based as CRB continues to evolve its plan for shoreline protection in this area. The pump station should be located in the “protected” area behind the shoreline adaptation, and the pump station discharge should be incorporated with the shoreline project.
- At present, CRB planning documents indicate that a berm could be constructed between the beach and parking lot. Based on this, the current concept includes a discharge in the same area. It is anticipated that the pump station would only be operated during extreme storm events when the beach is flooded. If the pump station were operated during a on-flood condition, discharge from the pump station would create beach erosion and be a hazard to beach occupants.

Figure 5: Design and Analysis Conditions vs. Historical Tide and Rainfall

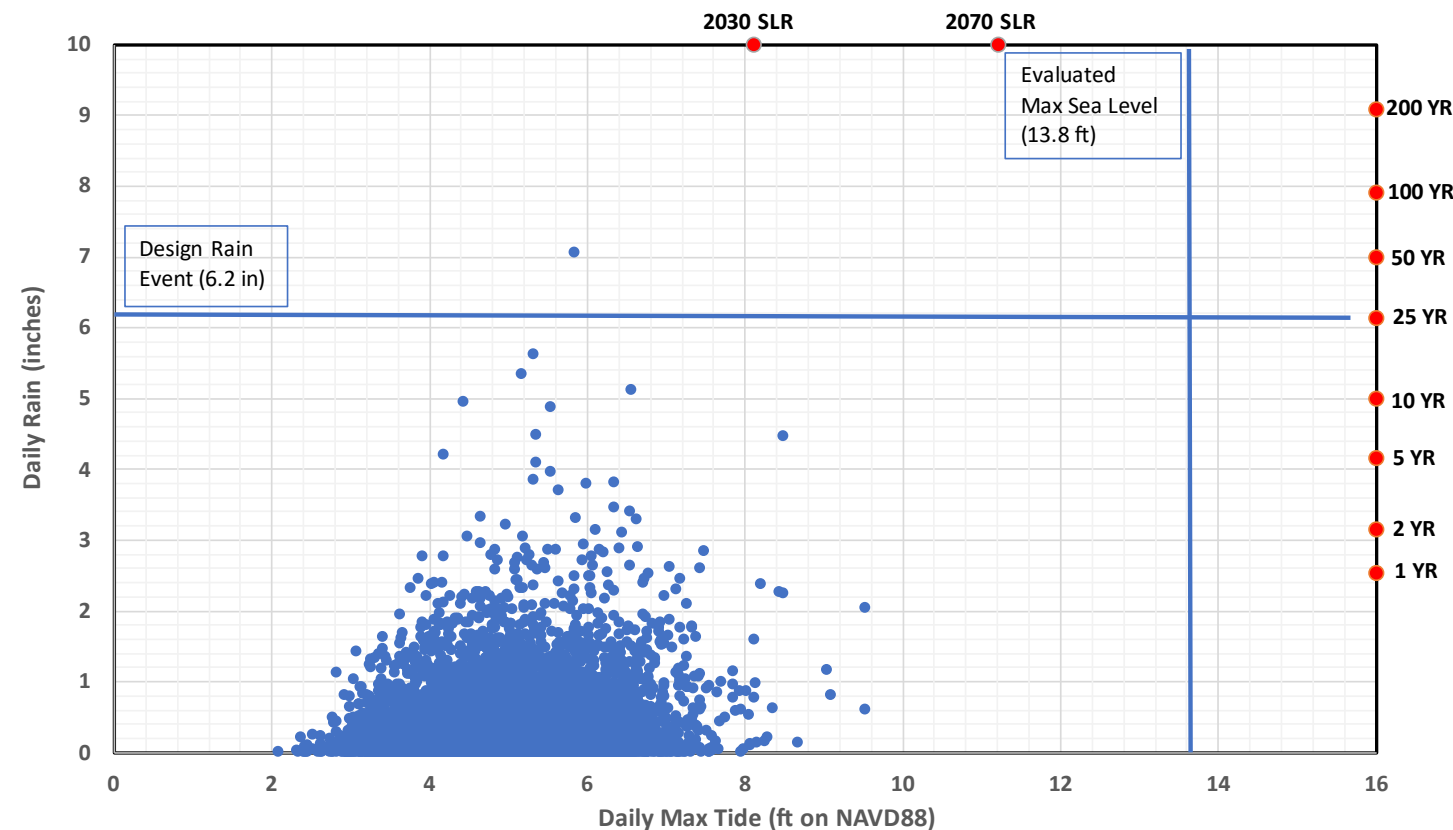

Coastal Stormwater Discharge Analysis
Constitution Beach



Hazen

Sheet 8 of 10

November 2022

Replicability and Implementation Timeline



Summary of Similar Concepts

Number of Sites: 24

Vulnerable Area: 464 acres

The map on this sheet depicts other vulnerable outfalls that could be adapted with electric submersible pump stations. In some locations, several outfalls could be consolidated with a new conduit that conveys flow to a single pump station.

Additional detail about these outfalls can be found in the Commission's Coastal Stormwater Discharge Analysis Implementation Timeline.

Coastal Stormwater Discharge Analysis
Constitution Beach



Hazen

Sheet 9 of 10

November 2022

ATTACHMENT A

CONSTITUTION BEACH PUMP STATION CONCEPTUAL DESIGN DRAWINGS

A-1: Overview Plan and Pump Station Plan

A-2: Pump Station Section View

Coastal Stormwater Discharge Analysis
Constitution Beach



Hazen

Sheet 10 of 10

November 2022

Constitution Beach Stormwater Pump Station

NOTES

1. FOR WATER SURFACE ELEVATIONS REFER TO OPERATIONAL TABLE.
2. ALL ELEVATIONS USE THE NAVD88 VERTICAL DATUM UNLESS OTHERWISE STATED.
3. CONCEPTUAL DRAWING, NOT FOR CONSTRUCTION.

STORMWATER PUMP-1,2,3 OPERATIONAL PARAMETERS	
FLOW RATE, CFS	74
STATIC HEAD RANGE, FT	13.3 - 20.5
DESIGN FLOOD ELEVATION, FT	16.0

STORMWATER PUMP-1,2,3 OPERATIONAL WSE TABLE		
NOTE	OPERATION	ELEVATION, FT
A	HIGH LEVEL ALARM	2.7
B	LAG PUMP ON	1.0
C	LEAD PUMP ON	-0.5
D	LEAD PUMP OFF	-1.5
E	LOW LOW ALARM	-2.5
G	MIN PUMP SUBMERGENCE	-3.5

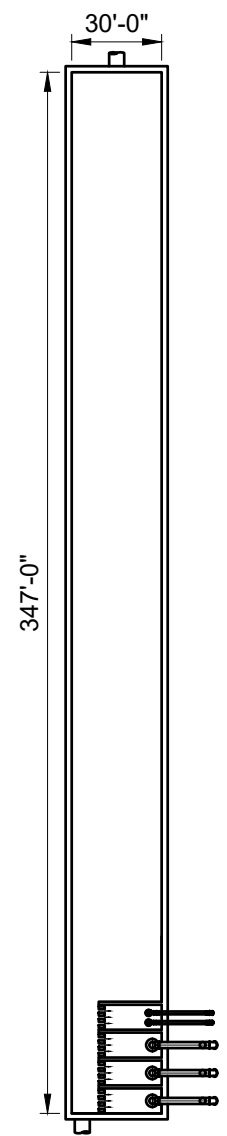

OVERVIEW PLAN
SCALE: NTS

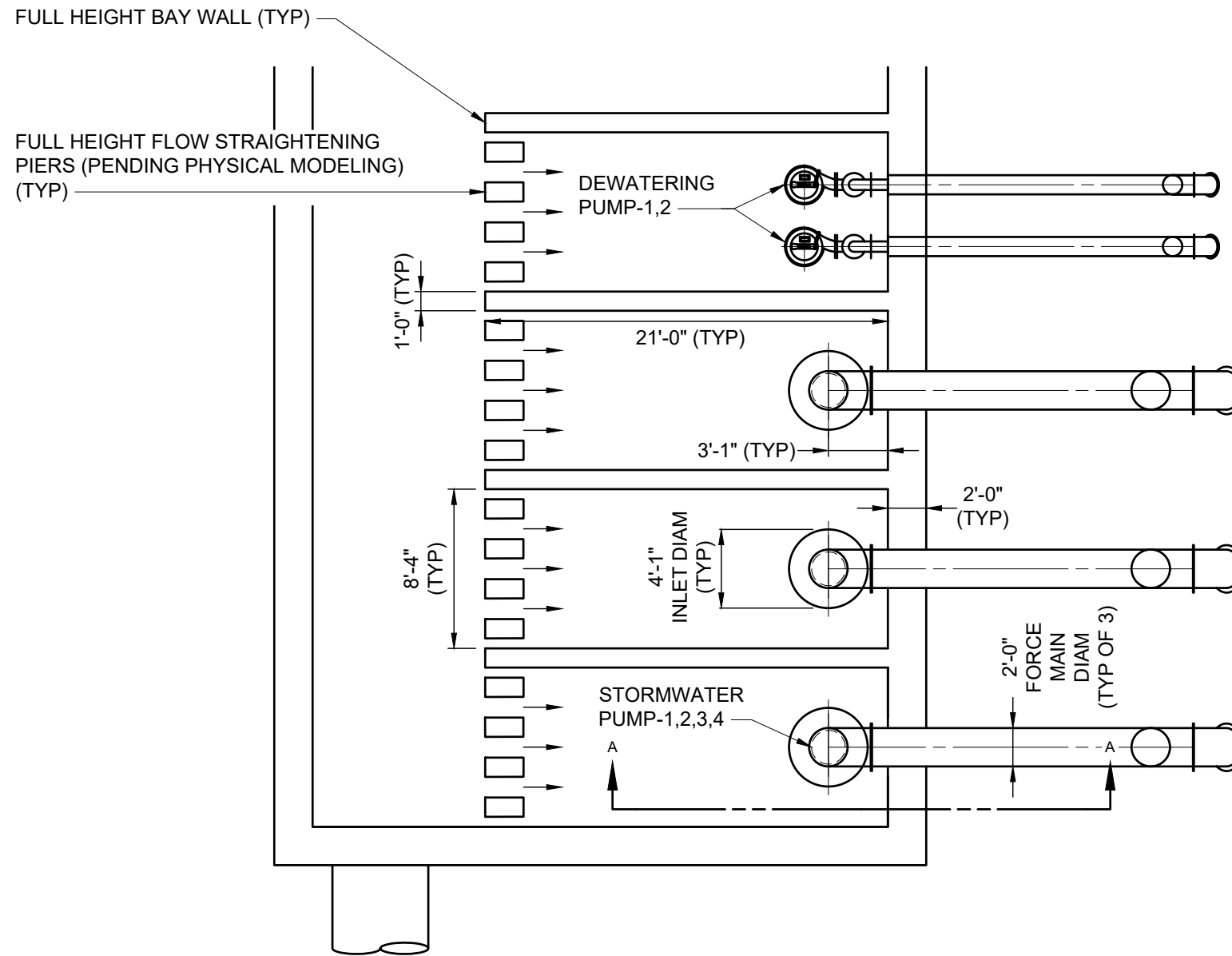

PUMP STATION PLAN
SCALE: NTS

COASTAL STORMWATER DISCHARGE ANALYSIS	
A-1	November 2022

Constitution Beach Stormwater Pump Station



NOTES

1. FOR WATER SURFACE ELEVATIONS REFER TO OPERATIONAL TABLE.
2. ALL ELEVATIONS USE THE NAVD88 VERTICAL DATUM UNLESS OTHERWISE STATED.
3. CONCEPTUAL DRAWING, NOT FOR CONSTRUCTION.

STORMWATER PUMP-1,2,3 OPERATIONAL PARAMETERS	
FLOW RATE, CFS	74
STATIC HEAD RANGE, FT	13.3 - 20.5
DESIGN FLOOD ELEVATION, FT	16.0

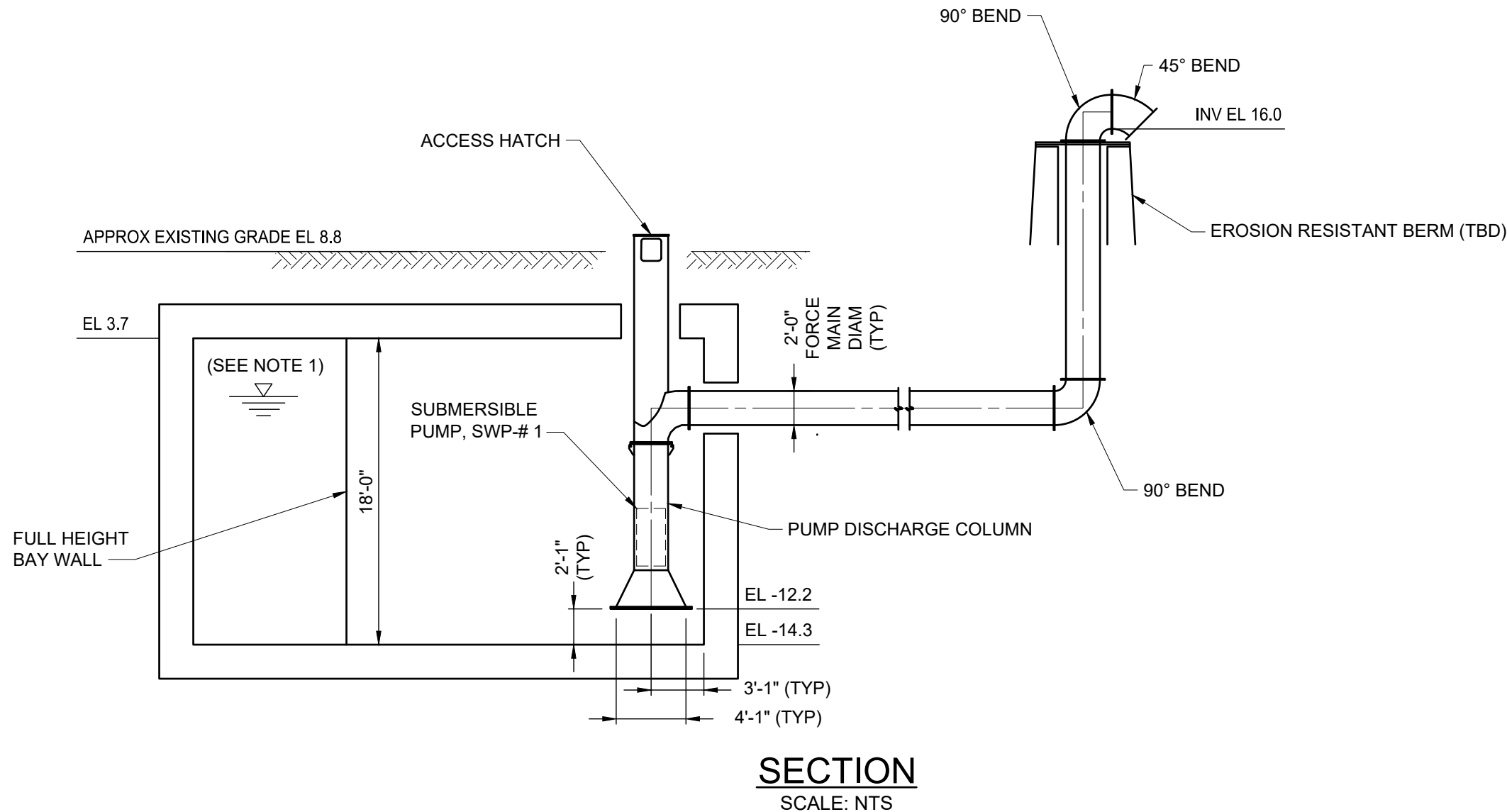
STORMWATER PUMP-1,2,3 OPERATIONAL WSE TABLE		
NOTE	OPERATION	ELEVATION, FT
A	HIGH LEVEL ALARM	2.7
B	LAG PUMP ON	1.0
C	LEAD PUMP ON	-0.5
D	LEAD PUMP OFF	-1.5
E	LOW LOW ALARM	-2.5
G	MIN PUMP SUBMERGENCE	-3.5



COASTAL STORMWATER DISCHARGE ANALYSIS	
	
A-2	November 2022